

EDWARDS ROGER G & FRANCIS RT 1 CLINTWOOD, VA 24228		
DATE RECORDED	4/11/69	
DEED OR WILL BOOK	134-643	
CONSIDERATION	YR - 5 SE 1,900	
DATE RECORDED		
DEED OR WILL BOOK		
CONSIDERATION		
DATE RECORDED		
DEED OR WILL BOOK		
CONSIDERATION		
DATE RECORDED		
DEED OR WILL BOOK		
CONSIDERATION		

CLASS	5	LEGAL DESCRIPTION	BIG RIDGE 24.81AC
ZONING			***
DISTRICT	RT 2		

1986	23,900	62,100	86,000
1987	23,900	62,100	86,000
1988	23,900	62,100	86,000
1989	23,900	62,100	86,000
1990	23,900	62,100	86,000
1991	23,900	62,100	86,000
1992			
1993			
1994			
1995			
1996			
1997			

BUILDING PERMITS					

NOTES:

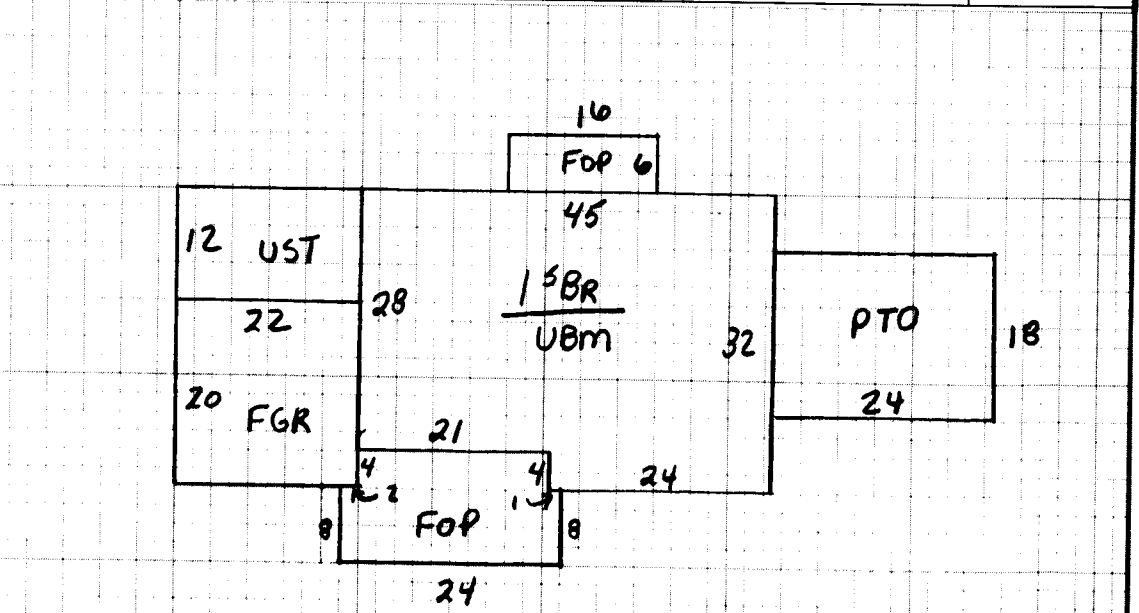

Dwelling	<input checked="" type="checkbox"/> Comp. Sh.	<input checked="" type="checkbox"/> Wood Siding	Yr. Built <b>92</b>	Remod.	Bmnt. [ ] 2nd [ ]	Plaster	BATH(S) / Full 1/2 Bath(s)
	Slate	Brick	No. Stories	1	1st <b>5</b> 3rd [ ]	Sheet rock	Modern Bath <input type="checkbox"/> Modern Kitchen <input type="checkbox"/>
	Asbestos	Asb. Wood Shg.	S. Level <input type="checkbox"/> S. Foyer <input type="checkbox"/>		Total No. Bedrooms	Ceciled	Cent. Heat <b>ELEC</b> A/C <input checked="" type="checkbox"/>
Wood Frame	<input checked="" type="checkbox"/> Metal	Cin. Block <input type="checkbox"/> Stone <input type="checkbox"/>				Panel	Fr. or Wall Furnace <input type="checkbox"/> Stove(s) <input type="checkbox"/>
Cin. Block	Tar & Grav.	Stucco <input type="checkbox"/> Con. Block <input type="checkbox"/>	Crawl <input type="checkbox"/> Conc. <input type="checkbox"/>	HW <input type="checkbox"/> Pine <input type="checkbox"/> Carp. <input checked="" type="checkbox"/> Tile <input checked="" type="checkbox"/>		Unfinished	
Steel Frame	Tile	Aluminum <input type="checkbox"/> Masonite <input type="checkbox"/>	Riers <input type="checkbox"/> Cin. Blk. <input type="checkbox"/>				
	Shakes	Storm Doors <input type="checkbox"/> Storm Win. <input type="checkbox"/>	Slab <input type="checkbox"/> Brick <input checked="" type="checkbox"/>	Disappearing Stairs		Gd. <input checked="" type="checkbox"/> Fair <input type="checkbox"/> Poor <input type="checkbox"/> VP <input type="checkbox"/>	Number
			Basement Size <b>100%</b>	Attic Floor & Stairs			Number Chimneys
			Basmt. Finish	1/4 <input type="checkbox"/> 1/2 <input type="checkbox"/> 3/4 <input type="checkbox"/> Full <input type="checkbox"/>	Attic <input type="checkbox"/> Walls <input type="checkbox"/> Fl. <input type="checkbox"/>		Brick <input checked="" type="checkbox"/> C. Block [ ]

**156R 1356 32 43,392**

Gd. <input checked="" type="checkbox"/> Fair <input type="checkbox"/> Poor <input type="checkbox"/> VP <input type="checkbox"/>	Basmt. Finish	1/4 <input type="checkbox"/> 1/2 <input type="checkbox"/> 3/4 <input type="checkbox"/> Full <input type="checkbox"/>	Attic <input type="checkbox"/> Walls <input type="checkbox"/> Fl. <input type="checkbox"/>	YR. <b>86</b>	YR.	YR.
---------------------------------------------------------------------------------------------------------------------------------	---------------	----------------------------------------------------------------------------------------------------------------------	--------------------------------------------------------------------------------------------	---------------	-----	-----

Dwelling			<b>C</b>		<b>66,256</b>	<b>-10%</b>	<b>59,630</b>
Porch	<b>332</b>	<b>10</b>					
Deck PTO	<b>432</b>	<b>4</b>					
Garage	<b>440</b>	<b>12</b>					
Cent. A/C	<b>1356</b>	<b>1</b>					
Basement	<b>1356</b>	<b>5</b>					
Basmt. Finish							
Attic	<b>240</b>	<b>10</b>					
Fireplace(s)							
Heating							
Bath(s)							
Total							
Factor							
Replacement							

**PAVED DRIVE  
MTL BLDG  
BARN**

**FV 1500  
FV 300  
FV 700**

M & L	M & L	MOBILE HOME INFORMATION	Market Value All Improvements	<b>62,130</b>
DATE	DATE	Owner	Market Value All Land	<b>23,905</b>
APRP.	APRP.	Make	Year	<b>86,035</b>
DATE	DATE	Size	Cond.	
CLASSIFICATION	ZONING	Not Home <input checked="" type="checkbox"/> Time		
<b>5</b>		AM <input checked="" type="checkbox"/> PM <input type="checkbox"/>		

**D.D.  
6/4/05**

USE VALUE APPRAISALS, RECAP	Land Cost	
	Bldg. Cost	
	Sale Price	
	Rent	
	Expenses	
	Net Rent	

PROPERTY FACTORS	CLASSIFICATION	ACRES	RATE	ADJ.	CLASSIFICATION	ACRES	RATE	ADJ.
Public Water <input checked="" type="checkbox"/> Paved	Home Site	<b>1</b>			Home Site			
Public Sewer <input checked="" type="checkbox"/> Gravel	<b>open parcel</b>	<b>10</b>	<b>1200</b>					
Well <input type="checkbox"/> Dirt	<b>HILLSIDE</b>	<b>13.81</b>	<b>500</b>					
Spring <input type="checkbox"/> No Road								
Septic System <input checked="" type="checkbox"/> Curb & Gutter	Wasteland				Wasteland			
J. G. Utilities <input type="checkbox"/> Sidewalk		<b>24.81</b>						
							<b>23,905</b>	

General Remarks:

LEVEL  SLOPES UP  SLOPES DOWN

LOW  STEEP UP  STEEP DOWN

BOARD REVIEW NOTES