

RECORD OF OWNERSHIP

AKERS RALPH EDWARDS C/O THOMAS L AKERS RT 1 BOX 351 NORA VA 24272 04453	DATE RECORDED	
	DEED OR WILL BOOK	N/A
	CONSIDERATION	YR- SE
	DATE RECORDED	
	DEED OR WILL BOOK	
	CONSIDERATION	
	DATE RECORDED	
	DEED OR WILL BOOK	
	CONSIDERATION	
	DATE RECORDED	
	DEED OR WILL BOOK	
	CONSIDERATION	
	DATE RECORDED	
	DEED OR WILL BOOK	
	CONSIDERATION	

CLASS	2			
ZONING	BRUSHY RIDGE 1 LOT ***			
DISTRICT	03			
1986	2000	3200	5200	
1987	2000	3200	5,200	
1988	2000	3200	5200	
1989	2000	3200	5200	
1990	2000	3200	5200	
1991	2000	3200	5200	
1992				
1993				
1994				
1995				
1996				
1997				

BUILDING PERMITS

NOTES:

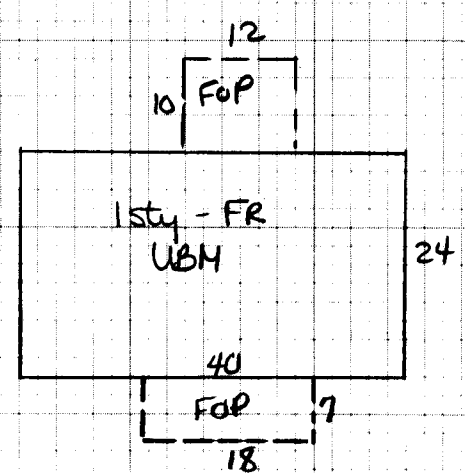

Dwelling <input checked="" type="checkbox"/>	Comp. Sh. <input checked="" type="checkbox"/>	Wood Siding	Yr. Built <u>61</u> Remod. <input type="checkbox"/>	Bsmt. [] 2nd []	Plaster	BATH(S) Full <input type="checkbox"/> 1/2 Bath(s) <input type="checkbox"/>
Slate	Brick	No. Stories <u>1</u>	1st <u>1 1/2</u> 3rd []	Sheet rock <input checked="" type="checkbox"/>	Modern Bath <input type="checkbox"/> Modern Kitchen <input type="checkbox"/>	
Asbestos	Aab. Wood Shg.	B. Level <input type="checkbox"/> S. Foyer <input type="checkbox"/>	Total No. Bedrooms	Ceciled	Cent. Heat <u>ELEC</u> A/C <input type="checkbox"/>	
Metal	Cin. Block <input type="checkbox"/> Stone <input type="checkbox"/>			Panel	Fir. or Wall Furnace <input type="checkbox"/> Stove(s) <input type="checkbox"/>	
Wood Frame <input checked="" type="checkbox"/>	Tar & Grav.	Stucco <input type="checkbox"/> Con. Block <input type="checkbox"/>	Crawl <input type="checkbox"/> Conc. <input type="checkbox"/>	HW <input type="checkbox"/> Pine <input type="checkbox"/> Carp. <input checked="" type="checkbox"/> Tile <input checked="" type="checkbox"/>	Unfinished	
Cin. Block	Tile	Aluminum <input checked="" type="checkbox"/> Masonite <input type="checkbox"/>	Riers <input type="checkbox"/> Cin. Bk. <input checked="" type="checkbox"/>			Number <u>NO</u>
Steel Frame	Shakes	Storm Doors <input type="checkbox"/> Storm Win. <input type="checkbox"/>	Slab <input type="checkbox"/> Brick <input type="checkbox"/>	Disappearing Stairs	Gd. <input type="checkbox"/> Fair <input type="checkbox"/> Poor <input type="checkbox"/> VP <input type="checkbox"/>	Number Chimneys
		Basement Size <u>100%</u>	Attic Floor & Stairs			Brick [] C. Block []
		Gd. <input type="checkbox"/> Fair <input checked="" type="checkbox"/> Poor <input type="checkbox"/> VP <input type="checkbox"/>	Bsmt. Finish	1/4 <input type="checkbox"/> 1/2 <input type="checkbox"/> 3/4 <input type="checkbox"/> Full <input type="checkbox"/>	Attic <input type="checkbox"/> Walls <input type="checkbox"/> Fl. <input type="checkbox"/>	Stone [] Metal []

1sty 960 31 29 760

YR. 1986 YR. YR.

Dwelling D 31 779 9% 3177

Porch 0 246 8 1968

Basement 960 5 4800

M & L	M & L
DATE	DATE
APRP. <u>J.S.</u>	APRP.
DATE <u>7-23-85</u>	DATE
CLASSIFICATION <u>2</u>	ZONING

MOBILE HOME INFORMATION	Market Value All Improvements <u>3200</u>
Owner	Market Value All Land <u>2000</u>
Make	<u>5200</u>
Year	
Size	
Cond.	
Not Home <input type="checkbox"/> Time	
AM <input type="checkbox"/> PM <input type="checkbox"/>	

Market Value All Improvements	<u>3200</u>
Market Value All Land	<u>2000</u>
Totals	<u>5200</u>

Total 36528
Factor 187
Replacement 31 779

Land Cost	\$
Bldg. Cost	\$
Sale Price	\$
Rent	\$
Expenses	\$
Net Rent	\$

PROPERTY FACTORS		CLASSIFICATION	ACRES	RATE	ADJ.	CLASSIFICATION	ACRES	RATE	ADJ.
Public Water	Paved	Home Site	<u>4</u>			Home Site		<u>2000</u>	
Public Sewer	Gravel								
Well	Dirt								
Spring	No Road <input checked="" type="checkbox"/>								
Septic System	Curb & Gutter	Wasteland				Wasteland			
U. G. Utilities	Sidewalk		<u>4</u>					<u>2000</u>	

General Remarks:

LEVEL SLOPES UP SLOPES DOWN

LOW STEEP UP STEEP DOWN

BOARD REVIEW NOTES