

HARRIS BOBBY LAWRENCE & PEARL RT A BOX 177 P.O. Box 324 BEE VA Downport, Va 24217 24239	DATE RECORDED	8-30-79
	DEED OR WILL BOOK	199-280
	CONSIDERATION	20,000
	DATE RECORDED	
	DEED OR WILL BOOK	
	CONSIDERATION	
	DATE RECORDED	
	DEED OR WILL BOOK	
	CONSIDERATION	
	DATE RECORDED	
	DEED OR WILL BOOK	
	CONSIDERATION	
	DATE RECORDED	
	DEED OR WILL BOOK	
	CONSIDERATION	

CLASS	2			LEGAL DESCRIPTION	INDIAN CREEK .25AC		
ZONING							
DISTRICT	02						
1992							
1993							
1994		3,500		30,800		34,300	
1995		3,500		30,800		34,300	
1996							
1997							
1998							
1999							
2000							
2001							
2002							
2003							

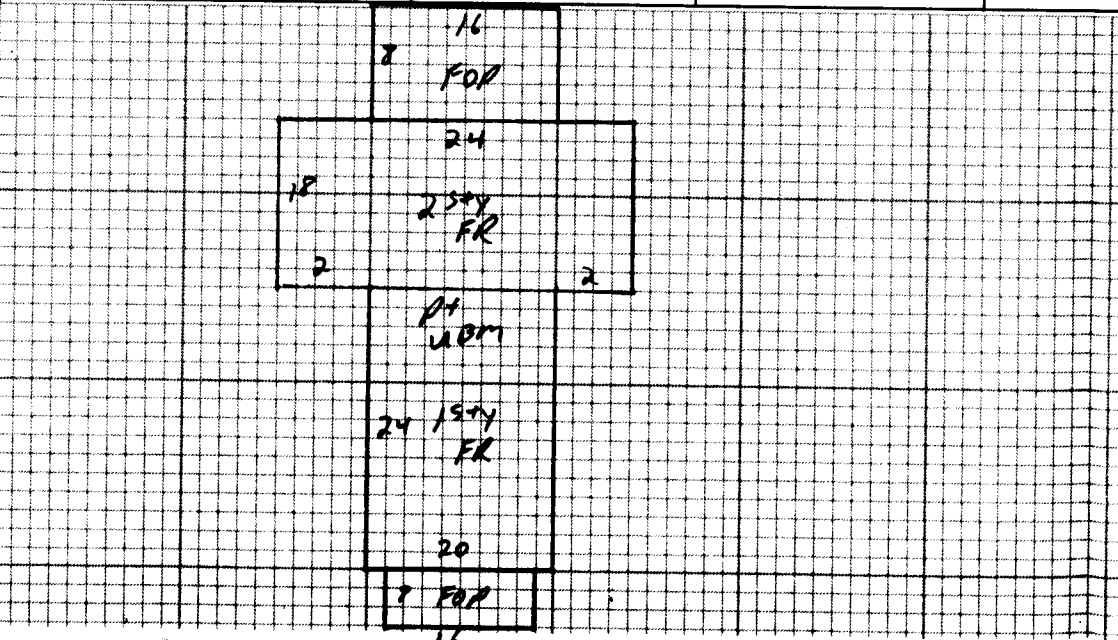

NOTES:

Dwelling	<input checked="" type="checkbox"/>	Comp. Sh.	<input checked="" type="checkbox"/>	Wood Siding		Yr. Built	Remod.	70's	Bemt.	[] 2nd []	Plaster		BATH(S) / Full	1/2 Bath(s)																										
		Slate		Brick		No. Stories		1+2	1st	[] 3rd []	Sheet rock	<input checked="" type="checkbox"/>	Modern Bath	<input type="checkbox"/> Modern Kitchen <input type="checkbox"/>																										
		Asbestos		Asb. Wood Shg.		B. Level	<input type="checkbox"/>	B. Foyer	<input type="checkbox"/>	Total No. Bedrooms	Ceiled		Cent. Heat	COAL A/C																										
		Metal		Cin. Block	<input type="checkbox"/>	Stone	<input type="checkbox"/>				Panel	<input checked="" type="checkbox"/>	Flr. or Wall Furnace	<input type="checkbox"/> Stove(s) <input checked="" type="checkbox"/>																										
Wood Frame	<input checked="" type="checkbox"/>	Tar & Grav.		Stucco	<input type="checkbox"/>	Con. Block	<input type="checkbox"/>	Crawl	<input type="checkbox"/>	Conc.	<input type="checkbox"/>	NW	<input type="checkbox"/>	Pine	<input type="checkbox"/>	Carp.	<input type="checkbox"/>	Tile	<input type="checkbox"/>	Unfinished			Number																	
Cin. Block		Tile		Aluminum	<input checked="" type="checkbox"/>	Masonite	<input type="checkbox"/>	Flers	<input type="checkbox"/>	Cin. Blk.	<input type="checkbox"/>													Number Chimneys																
Steel Frame		Shakes		Storm Doors	<input type="checkbox"/>	Storm Win.	<input type="checkbox"/>	Slab	<input type="checkbox"/>	Brick	<input type="checkbox"/>	Disappearing Stairs		Od.	<input type="checkbox"/>	Fair	<input type="checkbox"/>	Poor	<input type="checkbox"/>	VP	<input type="checkbox"/>			Brick	[] C. Block []															
								Basement Size	1/4			Attic Floor & Stairs												Stone	[] Metal []															
																								Basmt. Finish	1/4	1/4	1/2	3/4	Full	Attic	Walls	<input type="checkbox"/>	Fl.	<input type="checkbox"/>	YR.	94	YR.		YR.	

1+254 1344 285 38304 38304

Dwelling									07		38,487	20%	30789																								
Porch	0	256	8	2048																																	
Porch																																					
Carport																																					
Garage																																					
Cent. A/C																																					

Basement	228	65	1482	M & L		M & L				Market Value All Improvements	30800		
Basmt. Finish				DATE		DATE		Owner		Market Value All Land	3500		
Attic				APPR.	M5	APPR.		Make	Year		34,300		
Fireplace(s)				DATE	2-3-94	DATE		Size	Cond.				
Heating				CLASSIFICATION	2	ZONING		Not Home	Time				
Bath(s)								AM	PM				
Total	41834												
Factor	.92												
Replacement	38487												

Land Cost		
Bldg. Cost		
Sale Price		
Rent		
Expenses		
Net Rent		

CLASSIFICATION	ACRES	RATE	ADJ.	CLASSIFICATION	ACRES	RATE	ADJ.
Home Site	.25			Home Site		3500	
Wasteland				Wasteland		3500	

Public Water	Paved	<input checked="" type="checkbox"/>
Public Sewer	Gravel	
Well	Dirt	<input checked="" type="checkbox"/>
Spring	No Road	
Septic System	Curb & Gutter	<input checked="" type="checkbox"/>
U. G. Utilities	Sidewalk	

General Remarks:

LEVEL SLOPES UP SLOPES DOWN
 LOW STEEP UP STEEP DOWN

BOARD REVIEW NOTES