

SANDLICK DISTRICT

0000000007570

NOWLIN COY G & WIFE
~~RT 1 BOX 85~~ PO BOX 514
 HAYSI VA

24256

DATE RECORDED **5-76**
 DEED OR WILL BOOK **DB 0177 0339**

CONSID-ERATION

DATE RECORDED

DEED OR WILL BOOK

CONSID-ERATION

DATE RECORDED

DEED OR WILL BOOK

CONSID-ERATION

DATE RECORDED

DEED OR WILL BOOK

CONSID-ERATION

DATE RECORDED

DEED OR WILL BOOK

CONSID-ERATION

BUILDING PERMITS

NO.	TYPE	DATE	% COMP.	DATE FINAL	APPROVAL	APPROVAL

NOTES:

CLASS	LEGAL DESCRIPTION			
2	MCCLURE 10AC			
ZONING				
DISTRICT	04			
1992				
1993				
1994	9,400	62,000	71,400	
1995	9,400	62,000	71,400	
1996				
1997				
1998				
1999				
2000				
2001				
2002				
2003				

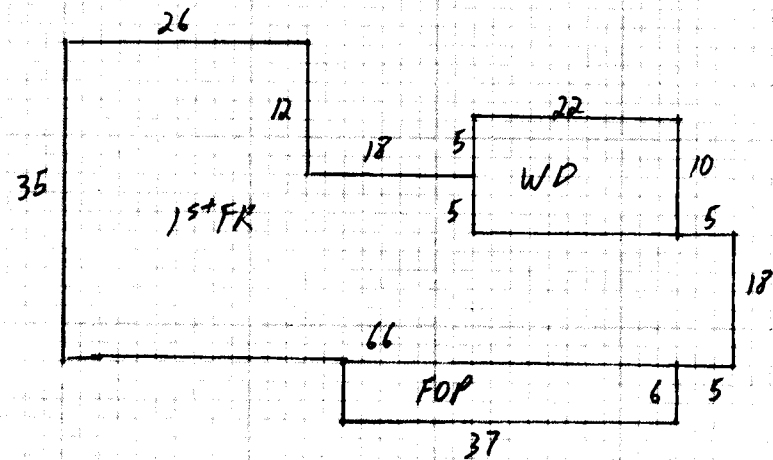

Dwelling	<input checked="" type="checkbox"/>	Comp. Sh.	<input checked="" type="checkbox"/>	Wood Siding		Yr. Built 70	Remod.	Bemt.	[]	2nd	[]	Plaster		BATH(S)	Full	1/2 Bath(s)					
		Slate		Brick		No. Stories		1st	<input checked="" type="checkbox"/>	3rd	[]	Sheet rock		Modern Bath	<input type="checkbox"/>	Modern Kitchen	<input type="checkbox"/>				
		Asbestos		Asb. Wood Shg.		S. Level	<input type="checkbox"/>	S. Foyer	<input type="checkbox"/>	Total No. Bedrooms		Ceciled		Cent. Heat	E/C	A/C	NO				
		Metal		Cin. Block	<input type="checkbox"/>	Stone	<input type="checkbox"/>					Panel	<input checked="" type="checkbox"/>	Fir. or Wall Furnace	<input type="checkbox"/>	Stove(s)	<input type="checkbox"/>				
Wood Frame	<input checked="" type="checkbox"/>	Tar & Grav.		Stucco	<input type="checkbox"/>	Con. Block	<input type="checkbox"/>	Crawl	<input type="checkbox"/>	Conc.	<input type="checkbox"/>	HW	<input type="checkbox"/>	Pine	<input type="checkbox"/>	Corp.	<input checked="" type="checkbox"/>	Tile	<input checked="" type="checkbox"/>	Unfinished	
Cin. Block		Tile		Aluminum	<input checked="" type="checkbox"/>	Masonite	<input type="checkbox"/>	Riers	<input type="checkbox"/>	Cin. Blk	<input checked="" type="checkbox"/>										
Steel Frame		Shakes		Storm Doors	<input type="checkbox"/>	Storm Win.	<input type="checkbox"/>	Slab	<input type="checkbox"/>	Brick	<input type="checkbox"/>	Disappearing Stairs		Gd.	<input type="checkbox"/>	Fair	<input checked="" type="checkbox"/>	Poor	<input type="checkbox"/>	VP	<input type="checkbox"/>

Basement Size	NO	Attic Floor & Stairs		Basmt. Finish		1/4	<input type="checkbox"/>	1/2	<input type="checkbox"/>	3/4	<input type="checkbox"/>	Full	<input type="checkbox"/>	Attic	<input type="checkbox"/>	Walls	<input type="checkbox"/>	Fl.	<input type="checkbox"/>	Stone	<input type="checkbox"/>	Metal	<input type="checkbox"/>
---------------	----	----------------------	--	---------------	--	-----	--------------------------	-----	--------------------------	-----	--------------------------	------	--------------------------	-------	--------------------------	-------	--------------------------	-----	--------------------------	-------	--------------------------	-------	--------------------------

15' FR	1720	285	49020																				
--------	------	-----	-------	--	--	--	--	--	--	--	--	--	--	--	--	--	--	--	--	--	--	--	--

	AREA	HTS	VALUE											YR.	YR.	YR.
Dwelling																
				15' Dwelling	21X50											
				Jr. Bldg												
				Jr. Barn												
				4 Jr. Bldgs												
				1 CB gar.	14X20											
Porch	222	6	1332													
Porch WD	310	6	1860													
Carport																
Garage																
Cent. A/C																

Basement	M & L	M & L	MOBILE HOME INFORMATION	Market Value All Improvements	63000
Basmt. Finish			Owner	Market Value All Land	9400
Attic	DATE	DATE	Make Year	TOTAL MARKET VALUE	71400
Fireplace(s)			Size Cond.	LIVE VALUE APPRAISAL RECORD	

Heating	APRP.	APRP.	Not Home	Time	Average	Use Value	Project and historic information
Bath(s)	DATE	DATE	AM	PM			
Total	54212						
Factor	83						
Replacement	44995						

FRONTS ON				LAND VALUE COMPUTATIONS				LAND VALUE COMPUTATIONS								
Frontage	Depth	Square Footage	Use Price	Depth Factor	Front Ft. Rate	TOTAL	ADJ.	15	Use Price	Depth Factor	Front Ft. Rate	TOTAL	ADJ.	15		

PROPERTY FACTORS		CLASSIFICATION				CLASSIFICATION			
Location	Street or Road	Home Site	ACRES	RATE	ADJ.	Home Site	ACRES	RATE	ADJ.
Public Water	Paved								
Public Sewer	Gravel	POOR	8						
Well	✓ Dirt								
Spring	No Road								
Septic System	✓ Curb & Gutter	Wasteland				Wasteland			
U. G. Utilities	Sidewalk		10	Total Value Land	9400	Total Value Land		Total Value Land	

General Remarks:

LEVEL SLOPES UP SLOPES DOWN

LOW STEEP UP STEEP DOWN