

RECORD OF OWNERSHIP

STROUTH KENNEY
RT 2 BOX ~~434~~ 456
COEBURN, VA 24230

DATE RECORDED 6-78
DEED OR WILL BOOK 191-642
CONSID-ERATION YR-SP 3500

06632

CLASS 2
ZONING
DISTRICT 03
LEGAL DESCRIPTION
LYONS FORK
2AC-
1.717 Ac

YEAR	VALUE OF LAND	VALUE OF IMPROV.	TOTAL VALUE
1986	4000	73600	77600
1987	4000	73600	77600
1988	3,000	73,600	76,600
1989	3000	74,700	77,700
1990	3000	74700	77700
1991	3000	74700	77700
1992			
1993			
1994			
1995			
1996			
1997			

DATE RECORDED	
DEED OR WILL BOOK	
CONSID-ERATION	
DATE RECORDED	
DEED OR WILL BOOK	
CONSID-ERATION	
DATE RECORDED	
DEED OR WILL BOOK	
CONSID-ERATION	
DATE RECORDED	
DEED OR WILL BOOK	
CONSID-ERATION	

BUILDING PERMITS

NO.	TYPE	DATE	% COMP.	DATE FINAL	APPRAISAL	APPRAISAL

NOTES: .203 AC JEFFREY W. BOGGS ET ALX 242-511

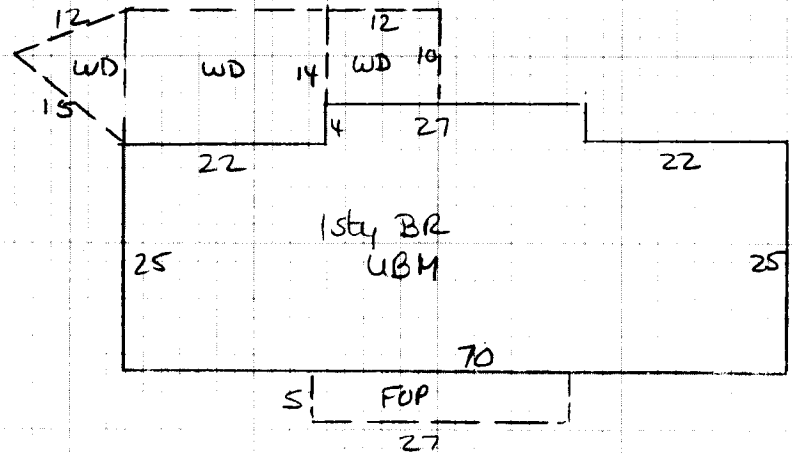

NOTES	MAIN BUILDING		ROOFING		EXTERIOR FINISH		GENERAL FEATURES		NUMBER OF ROOMS		INTERIOR FINISH		PLUMBING & HEATING	
	Dwelling		Comp. Sh.	Wood Siding	Yr. Built <u>83</u>	Remod.	Bsmt. [] 2nd []	Plaster	BATH(S) <u>2</u> Full <u>1/2</u> Bath(s)					
			Slate	Brick	No. Stories <u>1</u>	1st <u>17</u> 3rd []	Sheet rock	Modern Bath [] Modern Kitchen []						
			Asbestos	Asb. Wood Shg.	S. Level [] S. Foyer []	Total No. Bedrooms <u>3</u>	Ceciled	Cent. Heat [] A/C []						
	CONSTRUCTION		Metal	Cin. Block [] Stone []	FOUNDATION		FLOORS							
Wood Frame		Tar & Grav.	Stucco [] Con. Block []	Crawl [] Conc. []	HW [] Pine [] Carp. [] Tile []	Unfinished		Panel	Fr. or Wall Furnace [] Stove(s) []					
Cin. Block		Tile	Aluminum [] Masonite []	Riers [] Cin. Blk. []	ATTIC FINISH		INTERIOR CONDITION		Number <u>NO</u>					
Steel Frame		Shakes	Storm Doors [] Storm Win. []	Slab [] Brick []	Disappearing Stairs	Gd. [] Fair [] Poor [] VP []		Number Chimneys						

COMPUTATIONS				EXTERIOR CONDITION				SUMMARY OF BUILDINGS				INSULATION			
1stly 1858 31 57598				Gd. [] Fair [] Poor [] VP []				Basement Size <u>100%</u>				Attic Floor & Stairs			
				Basmt. Finish				1/4 [] 1/2 [] 3/4 [] Full []				Attic [] Walls [] Fl. []			

FRONTAGE	DEPTH	SQUARE FEET	USE	CLASS.	RATE	TOTAL APPRAISAL	USE VALUE	MARKET VALUE	MARKET VALUE	MARKET VALUE
BARN	1080	1	1080	Dwelling	C	71904	2%	70465		
				FR MISC BLDG	22x23	5	FV	2580		
				W/SUNLITES						
Porch	135	10	1350	MIL	MISC BLDG			NU		
Porch WD	452	4	1808	WD/TRAILER	4x5 12x21		FV	6000		
Carport				OP	12x27					
Garage				BARN	30x36			1100		
Cent. A/C	1858	1	1858	M & L	M & L			73600	74,700	
Basement	1858	5	9290	DATE	DATE			4000	3000	
Bsmt. Finish				APRP.	APRP.			77600	76000	
Attic				DATE	DATE					
Fireplace(s)				CLASSIFICATION	ZONING					
Heating				2						
Bath(s)										
Total										
Factor										
Replacement										

PROPERTY FACTORS		CLASSIFICATION	ACRES	RATE	ADJ.	TOTAL APPRAISAL	CLASSIFICATION	ACRES	RATE	ADJ.	TOTAL APPRAISAL
Public Water	Paved	Home Site	2.1717			3000 4600	Home Site				
Public Sewer	Gravel										
Well	Dirt										
Spring	No Road										
Septic System	Curb & Gutter	Wasteland	1.717			3000	Wasteland				
U. G. Utilities	Sidewalk		2			4600					

FRONTAGE TOPOGRAPHY		General Remarks:	
LEVEL [] SLOPES UP [] SLOPES DOWN []	SATellite DISH		
LOW [] STEEP UP [] STEEP DOWN []			

BOARD REVIEW NOTES