

ERVINTON DISTRICT

00000000003095

PATTON HERBERT C & EUNICE M BX 52 MCCLURE VA  24269	DATE RECORDED	7-26-72
	DEED OR WILL BOOK	DB 156-286
	CONSIDERATION	10,000
	DATE RECORDED	
	DEED OR WILL BOOK	
	CONSIDERATION	
	DATE RECORDED	
	DEED OR WILL BOOK	
	CONSIDERATION	
	DATE RECORDED	
	DEED OR WILL BOOK	
	CONSIDERATION	
	DATE RECORDED	
	DEED OR WILL BOOK	
	CONSIDERATION	

CLASS	2			LEGAL DESCRIPTION	MCCLURE LOT 57		
ZONING							
DISTRICT	02						
1992							
1993							
1994		2,500		26,900		29,400	
1995		2,500		26,900		29,400	
1996							
1997							
1998							
1999							
2000							
2001							
2002							
2003							

BUILDING PERMITS					
TYPE	DATE	NO.	APPLICANT	STATUS	REMARKS

NOTES:

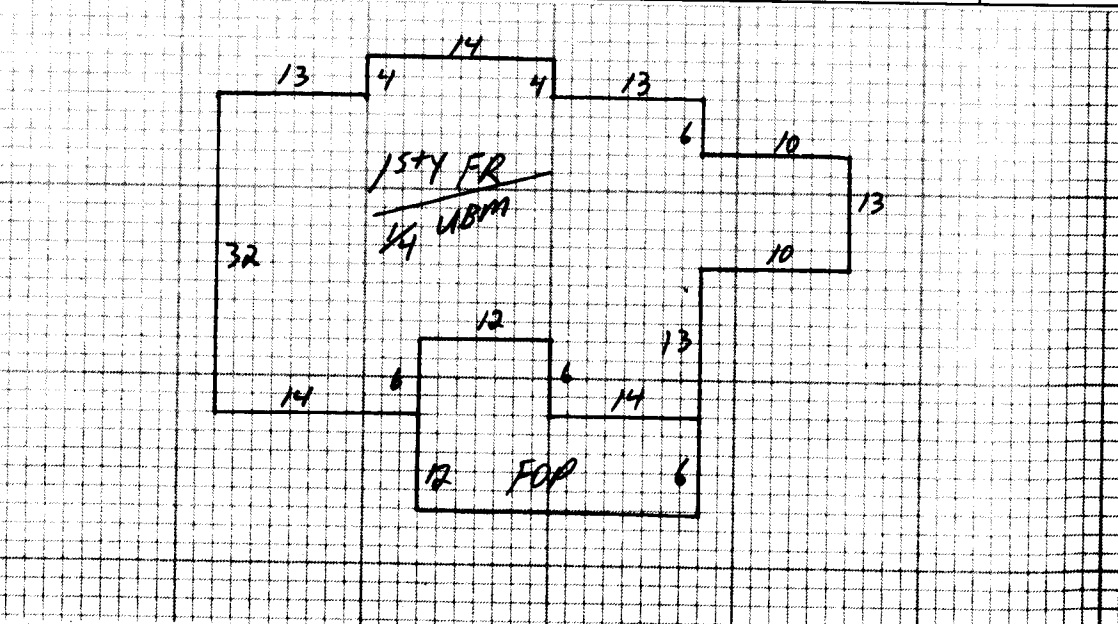

Dwelling	Comp. Sh.	Wood Siding	Yr. Built	Remod.	Bmnt.	1st	2nd	3rd	Plaster	BATH(s)	Full	1/2 Bath(s)
	Slate	Brick	No. Stories		1st	5	3rd		Sheet rock	Modern Bath		Modern Kitchen
	Asbestos	Aab. Wood Shg.	S. Level	S. Foyer	Total No. Bedrooms			Ceciled		Cent. Heat		A/C
	Metal	Cln. Block	Stone					Panel		Fir. or Wall Furnace		Stove(s)
Wood Frame	Tar & Grav.	Stucco	Con. Block	Crawl	Conc.	HW	Pine	Carp.	Tile	Unfinished		
Cln. Block	Tile	Aluminum	Masonite	Riers	Cln. Blk.							
Steel Frame	Shakes	Storm Doors	Storm Win.	Slab	Brick	Disappearing Stairs	Gd.	Fair	Poor	VP	Number	NO

Basement Size	1/4	Attic Floor & Stairs		Number Chimneys	
Gd. Fair Poor VP		Basmt. Finish		Brick	C. Block
		1/4 1/2 3/4 Full		Stone	Metal
				YR.	1994

1STY	1394	29	40,426									
				Dwelling		D		38,328	30%	26,829		
Porch	D	228	6	1368	CP	10X16			FU	100		
Porch												
Carport												
Garage												
Cent. A/C												
Basement	348	6.3	2262									

M & L	M & L	Market Value All Improvements	26900
DATE	DATE	Market Value All Land	2500
APPR	DR	APPR	29400
DATE	1-31-94	DATE	
CLASSIFICATION	2	ZONING	
Owner		Not Home	Time
Make	Year	Agric.	
Size	Cond.	Hort.	
		Forest	
		Open Space	
		Totals	

Total	44,056	Land Cost	
Factor	87	\$	
Replacement	38,328	Bldg. Cost	
		\$	
		Sale Price	
		\$	
		Rent	
		\$	
		Expenses	
		\$	
		Net Rent	
		\$	

CLASSIFICATION	ACRES	RATE	ADJ.	CLASSIFICATION	ACRES	RATE	ADJ.
Home Site	LOT		2500	Home Site			
Wasteland				Wasteland			
	LOT		2500				

General Remarks:

LEVEL  SLOPES UP  SLOPES DOWN

LOW  STEEP UP  STEEP DOWN

BOARD REVIEW NOTES