

Belcher Kerry, G & Robin R.
 P.O. Box 500
 Haysi, VA 24256

DATE RECORDED 5-13-91
 DEED OR WILL BOOK 272-675
 CONSIDERATION Gift

CLASS 4
 ZONING
 DISTRICT 09

LEGAL DESCRIPTION
 Russell Fork
 3.338 AC
 Sandlich

1992	6300	86400	92700	
1993	6300	86,400	92,700	
1994				
1995				
1996				
1997				
1998				
1999				
2000				
2001				
2002				
2003				

DATE RECORDED
 DEED OR WILL BOOK
 CONSIDERATION

DATE RECORDED
 DEED OR WILL BOOK
 CONSIDERATION

DATE RECORDED
 DEED OR WILL BOOK
 CONSIDERATION

DATE RECORDED
 DEED OR WILL BOOK
 CONSIDERATION

BUILDING PERMITS

NO.	TYPE	DATE	% COMP.	DATE FINAL	APPROVAL	APPROVAL

NOTES: From: Clayard Belcher # 12515

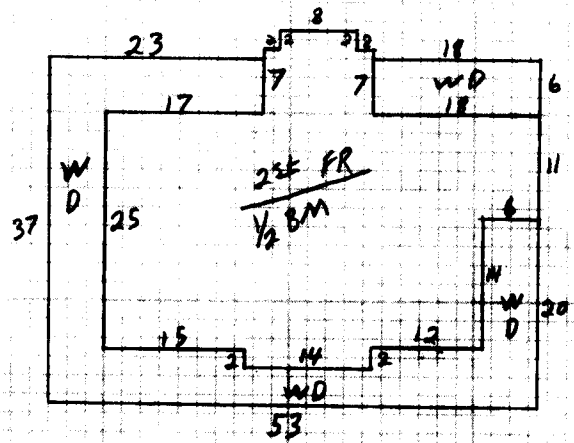

Dwelling	<input checked="" type="checkbox"/>	Comp. Sh.	<input checked="" type="checkbox"/>	Wood Siding		Yr. Built <u>91</u>	Remod.		Bemt. [] 2nd []	Plaster		BATH(S) Full [] 1/2 Bath(s) []
		Slate		Brick		No. Stories	<u>2</u>		1st [] 3rd []	Sheet rock	<input checked="" type="checkbox"/>	Modern Bath <input type="checkbox"/> Modern Kitchen <input type="checkbox"/>
		Asbestos		Asb. Wood Shg.		S. Level <input type="checkbox"/>	S. Foyer <input type="checkbox"/>		Total No. Bedrooms	Ceiled		Cent. Heat <u>HP</u> A/C <input checked="" type="checkbox"/>
		Metal		Cin. Block <input type="checkbox"/> Stone <input type="checkbox"/>						Panel		Fir. or Wall Furnace <input type="checkbox"/> Stove(s) <input type="checkbox"/>
Wood Frame	<input checked="" type="checkbox"/>	Tar & Grav.		Stucco <input type="checkbox"/> Con. Block <input type="checkbox"/>		Crawl <input type="checkbox"/> Conc. <input type="checkbox"/>			HW <input checked="" type="checkbox"/> Pine <input type="checkbox"/> Carp. <input type="checkbox"/> Tile <input type="checkbox"/>	Unfinished		
Cin. Block		Tile		Aluminum <input checked="" type="checkbox"/> Masonite <input type="checkbox"/>		Riers <input type="checkbox"/> Cin. Blk. <input type="checkbox"/>						
Steel Frame		Shakes		Storm Doors <input type="checkbox"/> Storm Win. <input type="checkbox"/>		Slab <input type="checkbox"/> Brick <input type="checkbox"/>			Disappearing Stairs		Gd. <input type="checkbox"/> Fair <input type="checkbox"/> Poor <input type="checkbox"/> VP <input type="checkbox"/>	Number <u>NO</u>

2nd FR 2169 31 67239

Gd. <input type="checkbox"/>	Fair <input type="checkbox"/>	Poor <input type="checkbox"/>	VP <input type="checkbox"/>	Basement Size	Attic Floor & Stairs		Number Chimneys
Basmt. Finish <u>1/2</u>							Brick [] C. Block []
							Stone [] Metal []

Porch WD 770 6 4620

Dwelling				B-		85782	D 1/2	85782		
FR Bldg									FK 400	
FR Bldg									FK 200	

Basement 600 9 3400

M & L	M & L		Market Value All Improvements	86400
DATE	DATE		Market Value All Land	7000
APRP <u>K.S.M.C.</u>	APRP		TOTAL MARKET VALUE	93400
DATE <u>10/7/91</u>	DATE			
CLASSIFICATION	ZONING			

Total 79428
Factor 1.08
Replacement 85782

CLASSIFICATION	ACRES	RATE	ADJ.	TOTAL
Home Site	1			4000
Home Site	2.338	306		701
Wasteland	M.N. 3.338	700		2337
Wasteland				7038

Public Water	Paved	<input checked="" type="checkbox"/>
Public Sewer	Gravel	<input checked="" type="checkbox"/>
Well	Dirt	
Spring	No Road	
Septic System	Curb & Gutter	<input checked="" type="checkbox"/>
U. G. Utilities	Sidewalk	

General Remarks:

LEVEL <input type="checkbox"/>	SLOPES UP <input type="checkbox"/>	SLOPES DOWN <input type="checkbox"/>
LOW <input type="checkbox"/>	STEEP UP <input type="checkbox"/>	STEEP DOWN <input type="checkbox"/>

BOARD REVIEW NOTES