

RECORD OF OWNERSHIP

CLASS	LEGAL DESCRIPTION			
1	GRAND VIEW ADD			
ZONING	.6AC			
DISTRICT	06			
YEAR	VALUE OF LAND	IMPROVEMENTS	TOTAL VALUE	TAXES
1992				
1993				
1994	5,000	56,400	61,400	
1995	5,000	56,400	61,400	
1996				
1997				
1998	5,000	56,400	61,400	
1999				
2000				
2001				
2002				
2003				

<del>WHITE MAX &amp; BONITA</del> BOX 1220 <del>3406 Locust St.</del> CLINTWOOD VA West Kes Moines 24228 I.A. 50265-4033	DATE RECORDED	8-23-79
	DEED OR WILL BOOK	DB 0199 0319
	CONSIDERATION	72,000
Whitt STUART W. ETAL	DATE RECORDED	10-21-97
Po Box 1626	DEED OR WILL BOOK	330-688
CLINTWOOD, VA 24228	CONSIDERATION	86000
	DATE RECORDED	
	DEED OR WILL BOOK	
	CONSIDERATION	
	DATE RECORDED	
	DEED OR WILL BOOK	
	CONSIDERATION	
	DATE RECORDED	
	DEED OR WILL BOOK	
	CONSIDERATION	

BUILDING PERMITS

NO.	TYPE	DATE	% COMP.	DATE FINAL	APPROVAL	APPROVAL

NOTES:

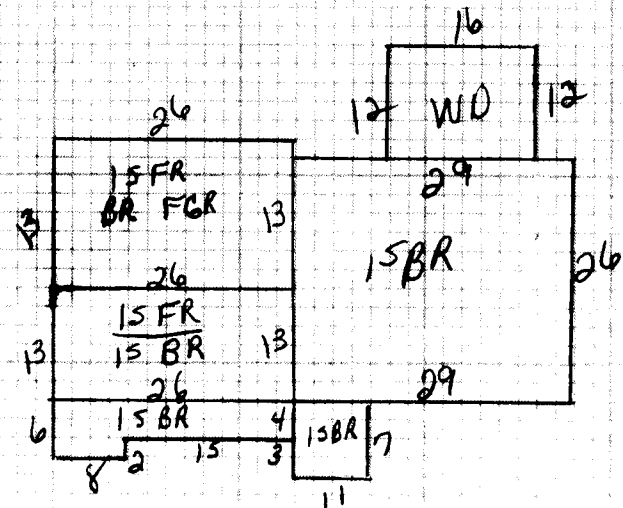

Dwelling	✓	Comp. Sh.	✓	Wood Siding	✓	Yr. Built 75	Remod.	Bemt. [ ] 2nd [3]	Plaster	BATH(S) 2 Full 1/2 Bath(s)
		Slate		Brick	✓	No. Stories	2	1st [5] 3rd [1]	Sheet rock	Modern Bath <input type="checkbox"/> Modern Kitchen <input type="checkbox"/>
		Asbestos		Asb. Wood Shg.		S. Level <input type="checkbox"/> S. Foyer <input type="checkbox"/>		Total No. Bedrooms	Ceclled	Cent. Heat elec A/C ✓
		Metal		Cin. Block <input type="checkbox"/> Stone <input type="checkbox"/>					Panel	Fir. or Wall Furnace <input type="checkbox"/> Stove(s) <input type="checkbox"/>
Wood Frame	✓	Tar & Grav.		Stucco <input type="checkbox"/> Con. Block <input type="checkbox"/>		Crawl <input type="checkbox"/> Conc. <input type="checkbox"/>		HW <input type="checkbox"/> Pine <input type="checkbox"/> Carp. <input checked="" type="checkbox"/> Tile <input type="checkbox"/>	Unfinished	
Cin. Block		Tile		Aluminum <input type="checkbox"/> Masonite <input type="checkbox"/>		Riers <input type="checkbox"/> Cin. Blk. <input type="checkbox"/>				
Steel Frame		Shakes		Storm Doors <input type="checkbox"/> Storm Win. <input type="checkbox"/>		Slab <input type="checkbox"/> Brick <input checked="" type="checkbox"/>		Disappearing Stairs	Gd. <input type="checkbox"/> Fair <input type="checkbox"/> Poor <input type="checkbox"/> VP <input type="checkbox"/>	Number 1

TYPE	SIZE	RATE	VALUE	TYPE	SIZE	RATE	VALUE	TYPE	SIZE	RATE	VALUE	TYPE	SIZE	RATE	VALUE
1 <sup>st</sup> BR	862	32	27,584												
2 <sup>nd</sup> FR	338	29	9,802												
2 <sup>nd</sup> BR	338	32	10,816												
1 <sup>st</sup> FR	390	29	11,310												
	1928														
Porch	77	8	616												
Porch WD	1012	6	1152												
Carport															
Garage	390	10	3900												
Cent. A/C	1928	1	1928												

Basement		M & L	M & L	MOBILE HOME INFORMATION	Market Value All Improvements	56000
Bemt. Finish		DATE	DATE	Owner	Market Value All Land	5000
Attic		APRP.	APRP.	Make	TOTAL MARKET VALUE	61400
Fireplace(s)	2000	DATE	DATE	Size		
Heating		CLASSIFICATION	ZONING	Not Home <input type="checkbox"/> Time		
Bath(s)				AM <input type="checkbox"/> PM <input type="checkbox"/>		
Total	69108					
Factor	90					
Replacement	66343					

FRONTAGE						LAND VALUE COMPUTATIONS						LAND VALUE COMPUTATIONS					
Frontage	Depth	Square Footage	Unit Price	Depth Factor	Front Pl. Rate	TOTAL	Adj.	TOTAL APPRAISAL	Unit Price	Depth Factor	Front Pl. Rate	TOTAL	Adj.	TOTAL APPRAISAL			

PROPERTY FACTORS				CLASSIFICATION	ACRES	RATE	ADJ.	CLASSIFICATION	ACRES	RATE	ADJ.
Utilities	Street or Road			Home Site				Home Site			
Public Water	✓	Paved	✓		.6					5000	
Public Sewer	✓	Gravel									
Well		Dirt									
Spring		No Road									
Septic System		Curb & Gutter		Wasteland				Wasteland			
U. G. Utilities		Sidewalk			.6					5000	
				Total Value Land				Total Average			Total Value Land

General Remarks:

LEVEL  SLOPES UP  SLOPES DOWN

LOW  STEEP UP  STEEP DOWN

BOARD REVIEW NOTES