

RECORD OF OWNERSHIP

SCARDO JOE A & NANCY G
BOX 248
CLINTWOOD VA

24228

DATE RECORDED	
DEED OR WILL BOOK	DB
CONSIDERATION	
DATE RECORDED	
DEED OR WILL BOOK	
CONSIDERATION	
DATE RECORDED	
DEED OR WILL BOOK	
CONSIDERATION	
DATE RECORDED	
DEED OR WILL BOOK	
CONSIDERATION	
DATE RECORDED	
DEED OR WILL BOOK	
CONSIDERATION	

CLASS	1
ZONING	
DISTRICT	06

LEGAL DESCRIPTION
1.25AC

YEAR	VALUE OF LAND	VALUE OF IMPROV	TOTAL VALUE
1992			
1993			
1994	6,000	31,600	37,600
1995	6,000	31,600	37,600
1996			
1997			
1998	6,000	31,600	37,600
1999			
2000			
2001			
2002			
2003			

BUILDING PERMITS

NO.	TYPE	DATE	ISSUED	DATE FINAL	APPROVAL	REVISION

NOTES:

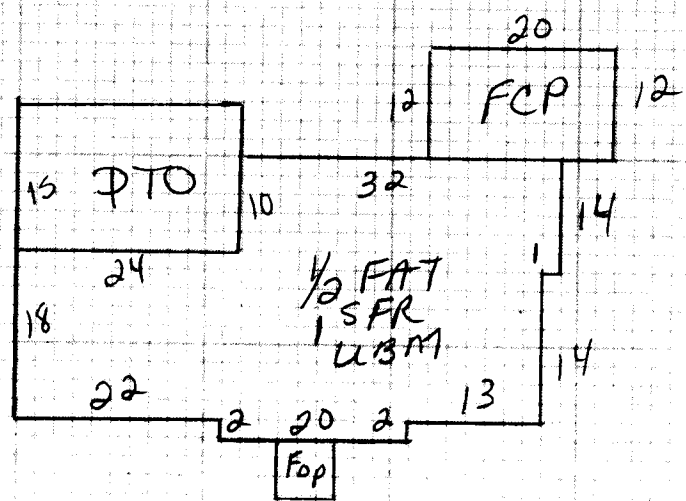

Dwelling	<input checked="" type="checkbox"/>	Comp. Sh.	<input checked="" type="checkbox"/>	Wood Siding		Yr. Built	50	Remod.		Bsmt.	[]	2nd	[]	Plaster		BATH(S) / Full	1/2 Bath(s)				
		Slate		Brick		No. Stories			1	1st	5	3rd	[]	Sheet rock	<input checked="" type="checkbox"/>	Modern Bath	<input type="checkbox"/>	Modern Kitchen	<input type="checkbox"/>		
		Asbestos		Asb. Wood Shg.	Comp <input checked="" type="checkbox"/>	S. Level	<input type="checkbox"/>	S. Foyer	<input type="checkbox"/>	Total No. Bedrooms				Ceciled		Cent. Heat		A/C			
		Metal		Cin. Block	<input type="checkbox"/>	Stone	<input checked="" type="checkbox"/>							Panel	<input checked="" type="checkbox"/>	Fir. or Wall Furnace	<input type="checkbox"/>	Stove(s)	<input type="checkbox"/>		
Wood Frame	<input checked="" type="checkbox"/>	Tar & Grav.		Stucco	<input type="checkbox"/>	Con. Block	<input type="checkbox"/>	Crawl	<input type="checkbox"/>	Conc.	<input type="checkbox"/>	HW	<input type="checkbox"/>	Pine	<input type="checkbox"/>	Carp.	<input type="checkbox"/>	Tile	<input type="checkbox"/>	Unfinished	
Cin. Block		Tile		Aluminum	<input type="checkbox"/>	Masonite	<input type="checkbox"/>	Riers	<input type="checkbox"/>	Cin. Blk.	<input type="checkbox"/>										
Steel Frame		Shakes		Storm Doors	<input type="checkbox"/>	Storm Win.	<input type="checkbox"/>	Slab	<input type="checkbox"/>	Brick	<input type="checkbox"/>	Disappearing Stairs		Gd.	<input checked="" type="checkbox"/>	Fair	<input type="checkbox"/>	Poor	<input type="checkbox"/>	VP	<input type="checkbox"/>

ITEM	SIZE	RATE	VALUE	BASE	VALUE	Gd.	<input type="checkbox"/>	Fair	<input checked="" type="checkbox"/>	Poor	<input type="checkbox"/>	VP	<input type="checkbox"/>	Basement Size	FULL	Attic Floor & Stairs		Brick	[]	C. Block	[]	Stone	[]	Metal	[]
1ST	1422	32	45504																						

Basement	1422	6.5	9243			M & L		M & L																	
Bsmt. Finish						DATE		DATE																	
Attic	711	8	5688			APRP.	JH	APRP.																	
Fireplace(s)						DATE	3/11/94	DATE																	
Heating						CLASSIFICATION	1	ZONING																	
Bath(s)																									
Total			60435																						
Factor			.83																						
Replacement			50161																						

FRONTS ON										LAND VALUE COMPUTATIONS										LAND VALUE COMPUTATIONS									
Frontage	Depth	Square Footage	Unit Price	Depth Factor	Front Ft. Rate	TOTAL	ADJ.	TOTAL APPRAISAL	Unit Price	Depth Factor	Front Ft. Rate	TOTAL	ADJ.	TOTAL APPRAISAL	Unit Price	Depth Factor	Front Ft. Rate	TOTAL	ADJ.	TOTAL APPRAISAL	Unit Price	Depth Factor	Front Ft. Rate	TOTAL	ADJ.	TOTAL APPRAISAL			
								94																					

PROPERTY FACTORS				CLASSIFICATION				CLASSIFICATION							
Utilities	Street or Road	Home Site	ACRES	RATE	ADJ.	Home Site	ACRES	RATE	ADJ.	Home Site	ACRES	RATE	ADJ.		
Public Water	Paved	1.25				6000									
Public Sewer	Gravel														
Well	Dirt														
Spring	No Road														
Septic System	Curb & Gutter														
U. G. Utilities	Sidewalk														
Total Average				Total Value Land				Total Average				Total Value Land			
1.25				6000				1.25				6000			

General Remarks: LEVEL SLOPES UP SLOPES DOWN LOW STEEP UP STEEP DOWN